

State of MBT in Germany

2-stage wet AD Process by example of MBT plant Lübeck

Dr.-Ing. Ketel Ketelsen / iba GmbH

recover Irish Recycling & Waste Management Show

24.-25.03.2009, Simmonscourt, Dublin

VITAE

Dr.-Ing. Ketel Ketelsen

Managing Director of the Engineering Consultancy for Waste and Energy Management GmbH (iba), Hanover

Chairman of the Advisory Council of Association for Material Specific Waste Treatment ASA e. V.

Chairman of VDI WG for directive No. 3475 Sheet 3, MBT and member in WG for directive No. 3459 Sheet 1, technical terms

Member of the BGS and Committee for the development of control criteria for RDF

State of MBT technology in Germany

MBS, MBD and MPD plants in Germany

<i>Federal state</i>	<i>Number of plants</i>	<i>Capacity t/y</i>
Brandenburg/Berlin	8	988,000
Bathe-Württemb.	1	100,000
Bavaria	1	40,000
Hesse	2	189,500
Mecklenburg-W. P.	3	380,000
Lower Saxony	10	970,100
North Rine-W.	6	885,000
Rhineland-P.	5	560,000
Saxonia-Anhalt	1	25,0000
Schleswig-Holst.	2	416,000
Saxonia	4	570,000
Thuringia	3	275,000
Total	46	5,398,600



Arbeitsgemeinschaft Stoffspezifische Abfallbehandlung

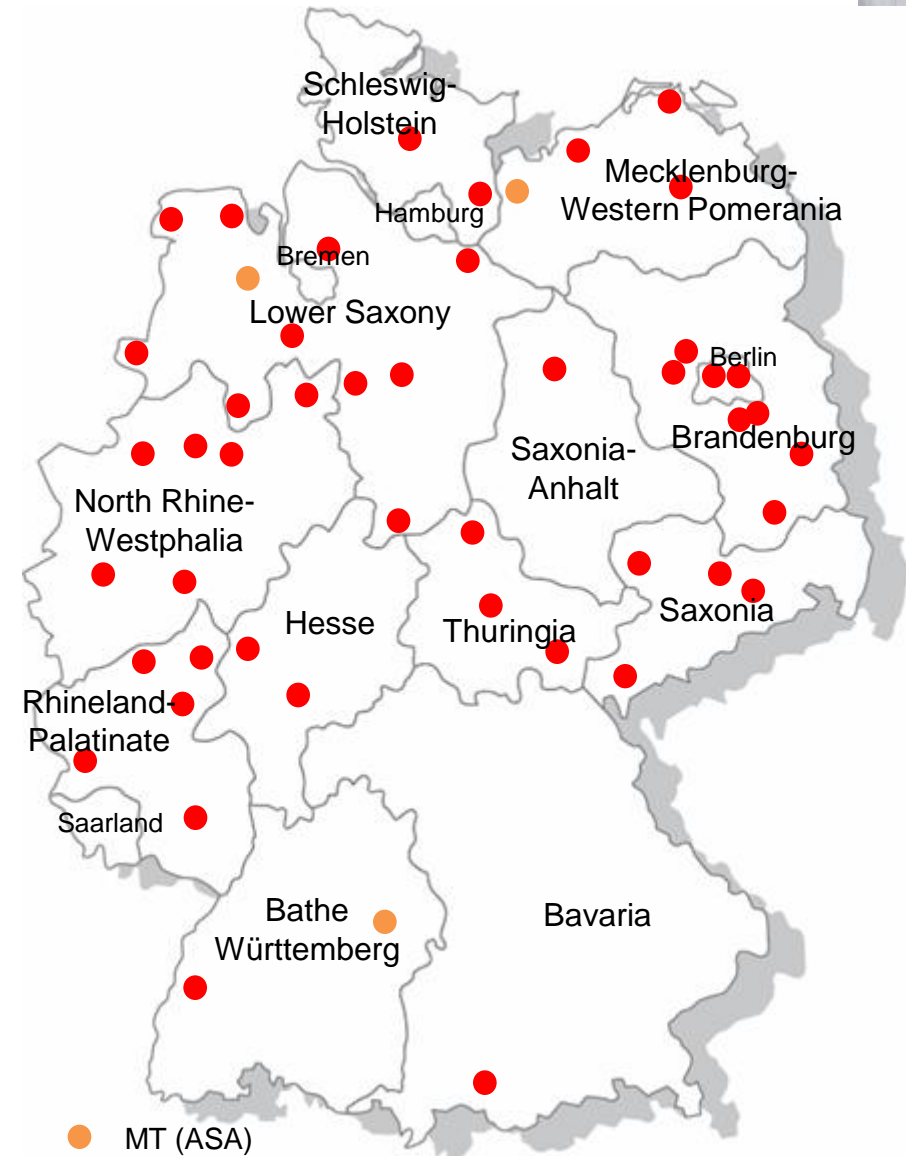

Development of MBT-capacity in Germany

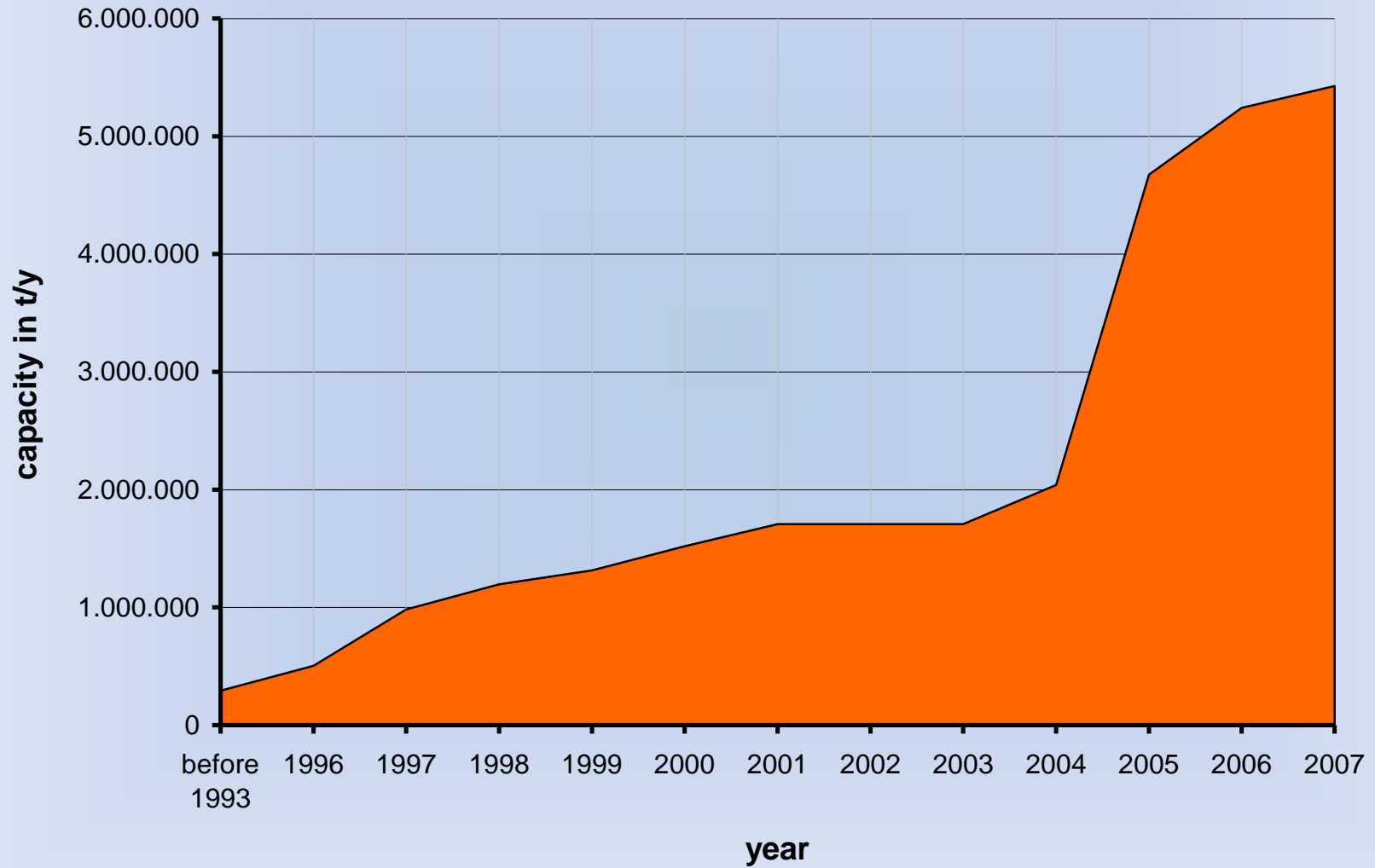

Old and new* MBT-plants in Germany

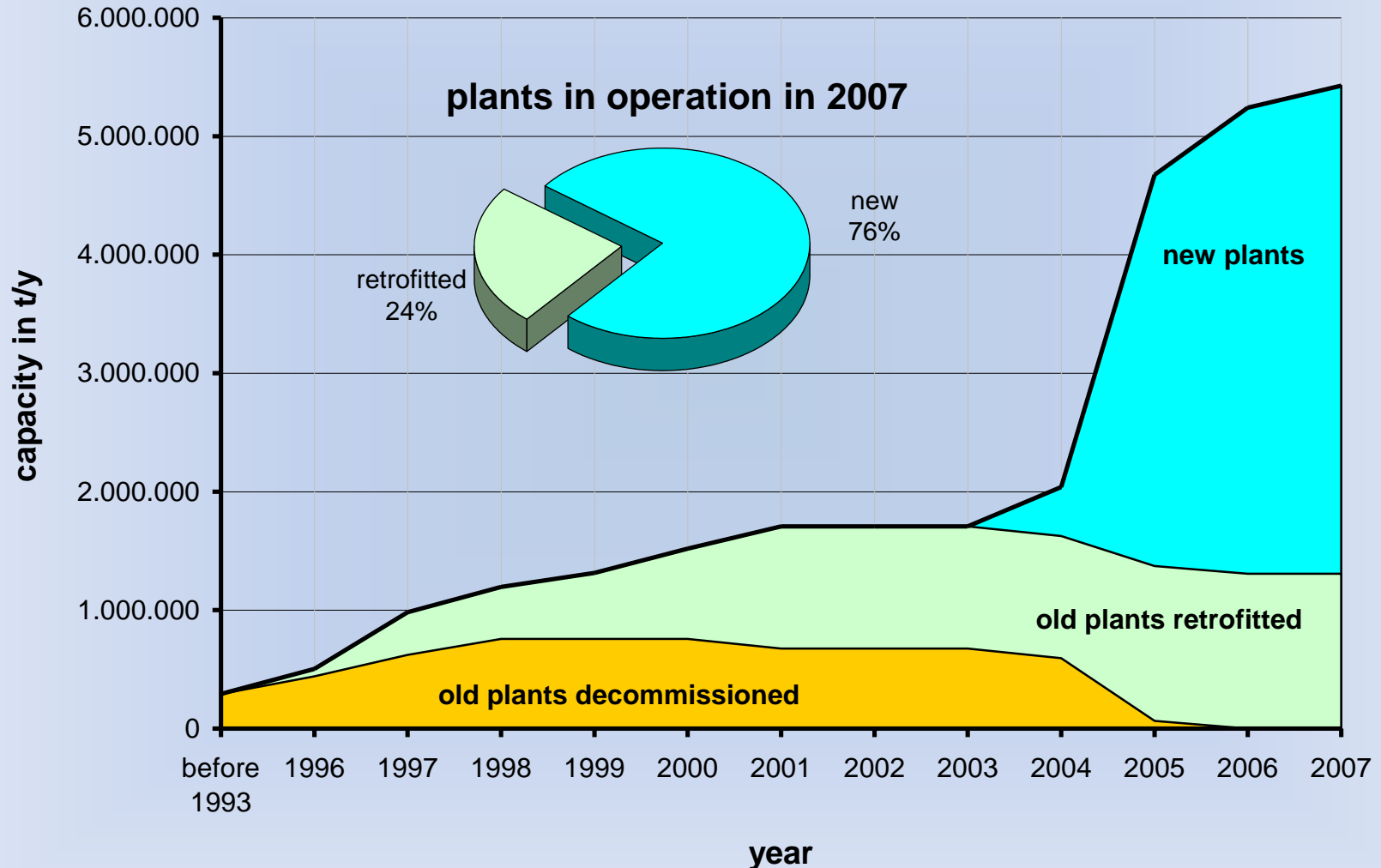

* According to German landfill ordinance, reference date: 01.06.2005



Reasons for the decision for the MBT technology

- Existing TASI landfills could further be used in connection with the MBT plants as well as further use of infrastructure
- Waste incineration was not often achievable against the resistance of the population
- Allegedly more favourable solution/smaller invest than with waste incineration
- Creation and/or protection of jobs by an own design capacity
- Creation of value remains in the region (orders to medium-size-companies)
- Good combination in connection with mono stream power plants or cement works or coal-fired power stations
- Saving of fossil fuels by the employment of Solid Recovered Fuels (SRF) in (mono stream) power stations and thus CO₂ saving
- Energy and fuel supplier for producing trade
- **Smaller, more flexible units, integration of AD for heat and power generation or upgrading to Biomethane**

MBS = Mechanical-Biological Stabilization (33 plants)

Is a combination of

- the mechanical processing with separation of high calorific fractions (to be used as RDF) as well as the valuable material for material recycling

and

- the biological treatment (decomposition, digestion) of the fine fraction for the reaching of the deposit criteria

MBD = Mechanical-Biological Drying (10 plants)

- the entire waste stream is dried before the mechanical processing biologically (under use of the self heating) and reduced by the organic components

MPD = Mechanical-Physical Drying (3 plants)

- mechanical processing with following drying process (e.g. by means of drum dryer), here fossil fuels for the drying process are used



State of MBT-technology in Germany

Portions of the pretreatment of residual-MSW

*only directly delivered MSW,
RDF additionally

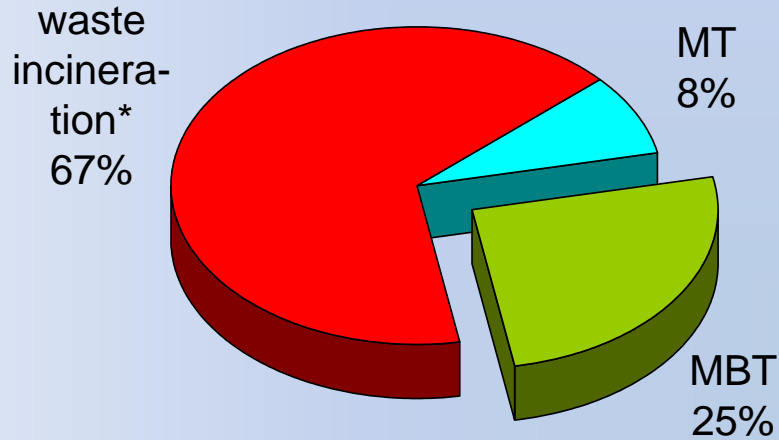

*approx. 33 % of the MSW
pre-treatment in MBT or MT*

Portions (capacity) of the MBT plant types

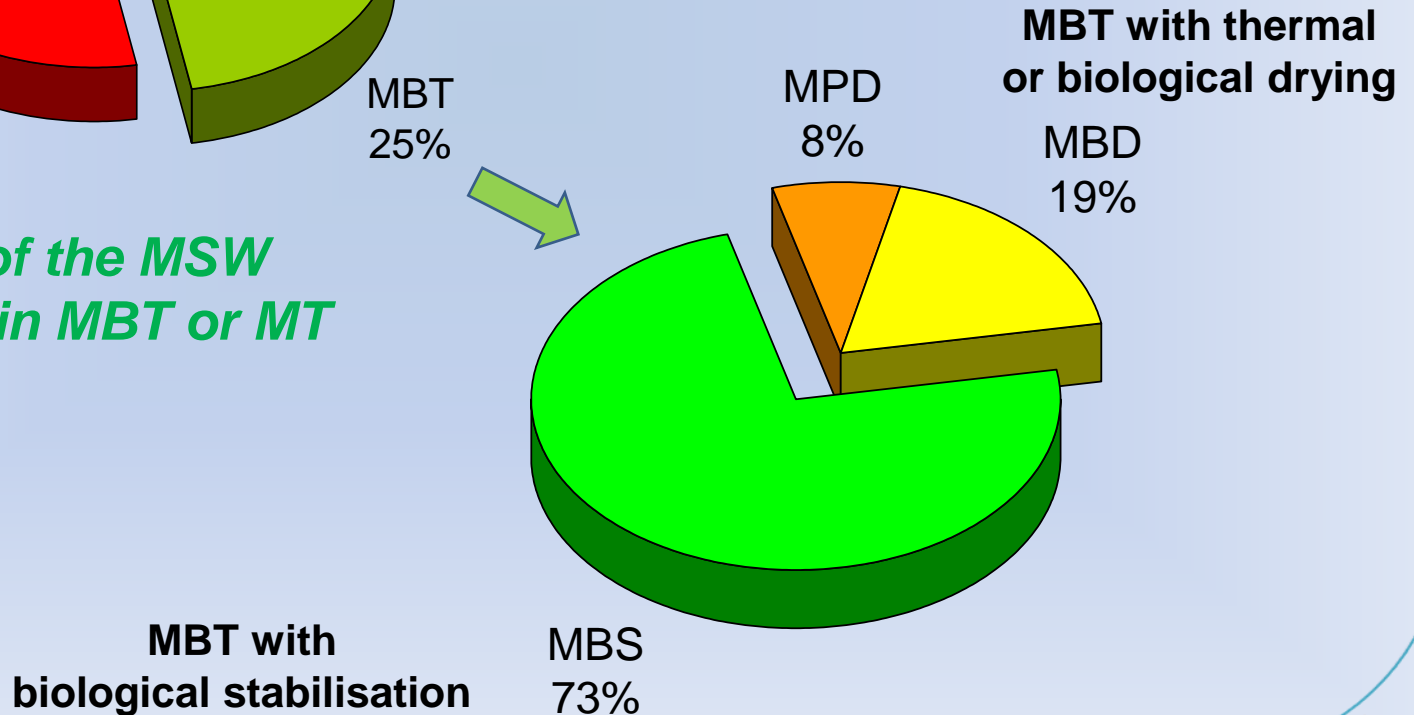

Composition of german MSW totally: 46.4 Mt (2006)

recycling rates organic
> 60% sep. collected

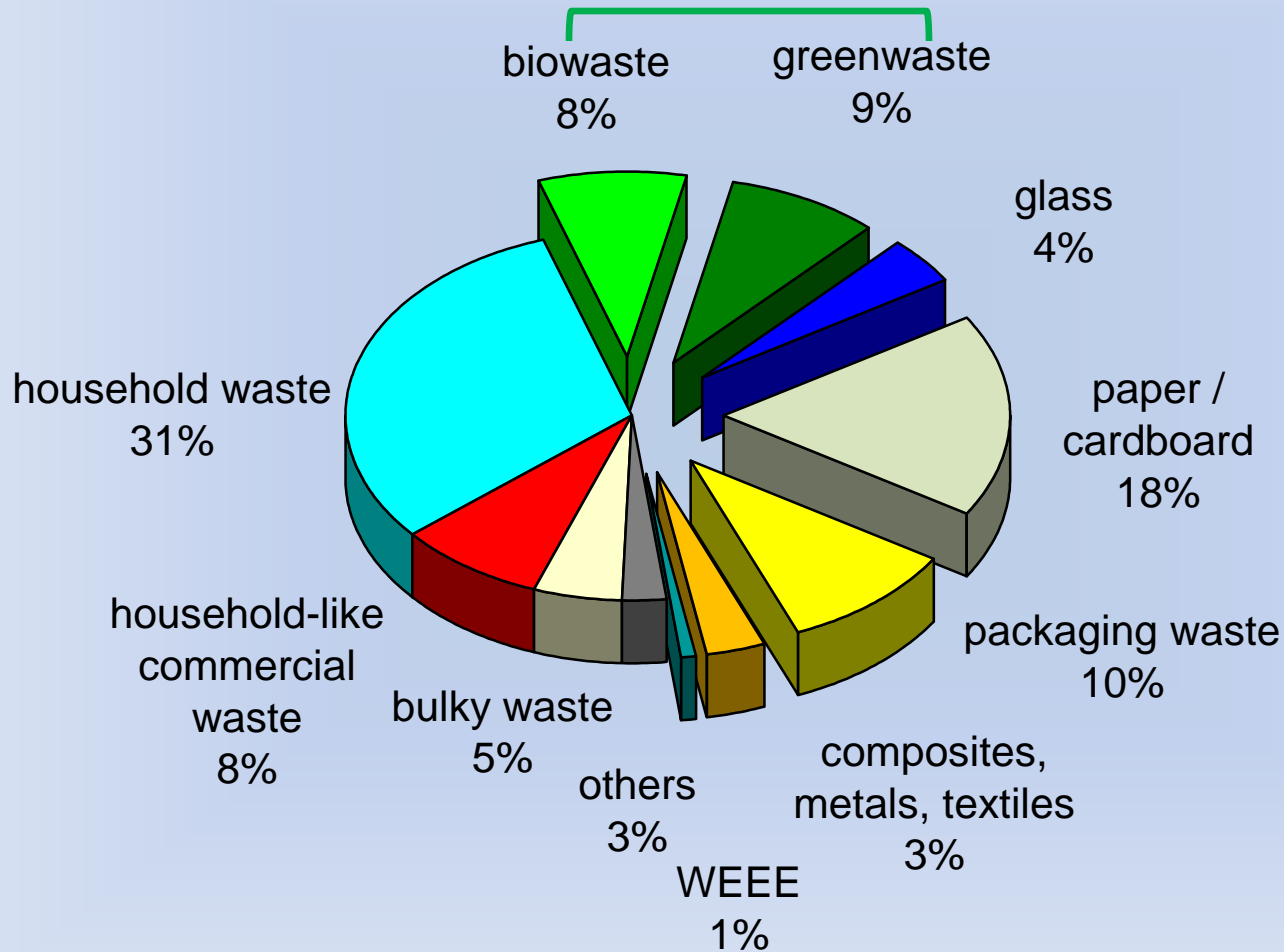

recycling rates
MSW
➤ 50% sep.
➤ collected

Approx. 21 Mt residual MSW

Composition of german residual MSW* (2006: approx. 21.0 Mt/y)

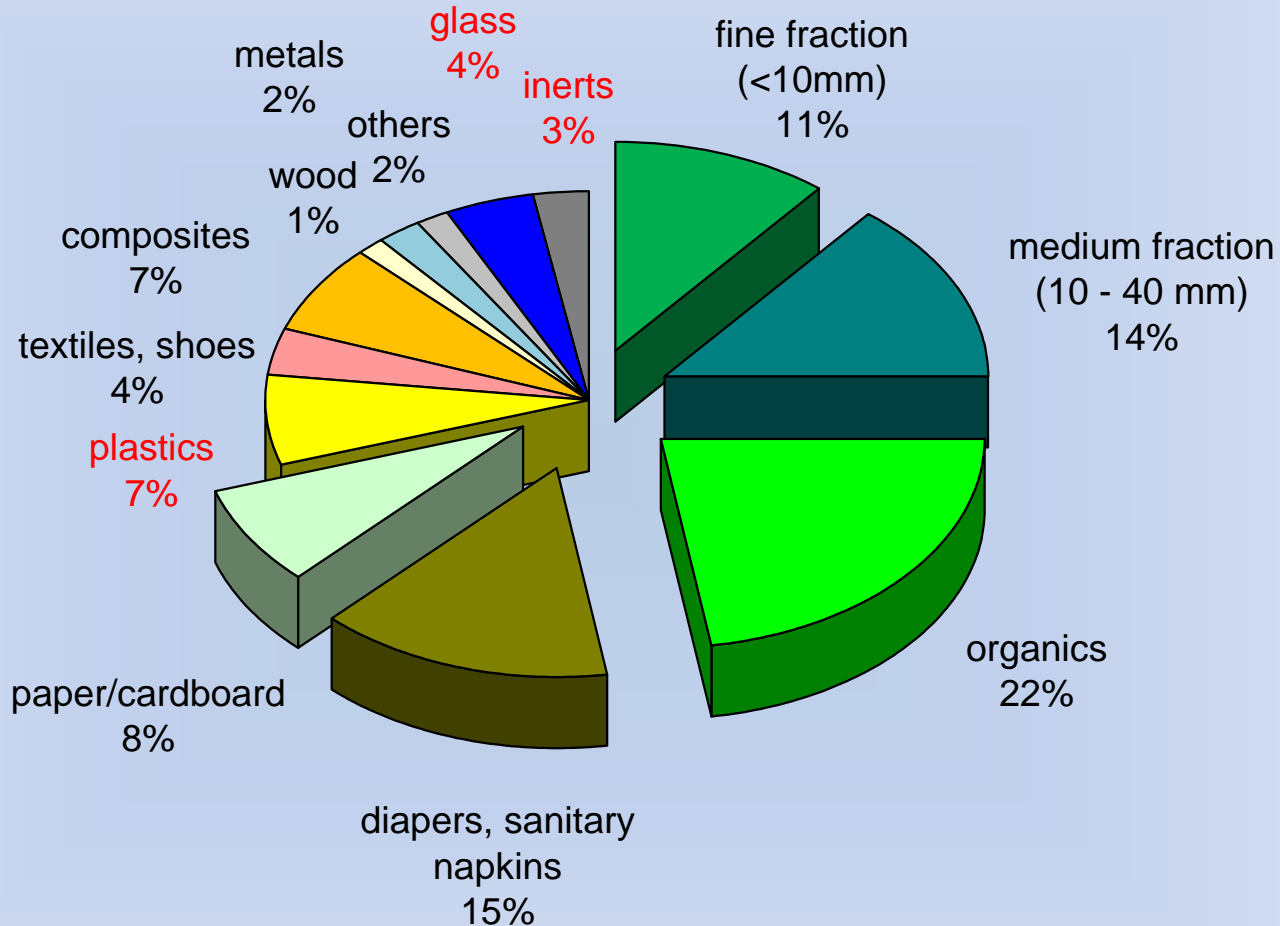

**50 - 80 % BMW in residual MSW;
thereof suitable for MBT (depending on technology): 40 – 60 %**

*example, from Weigand and Marb, 2005

Material balance in MBS (example / average)

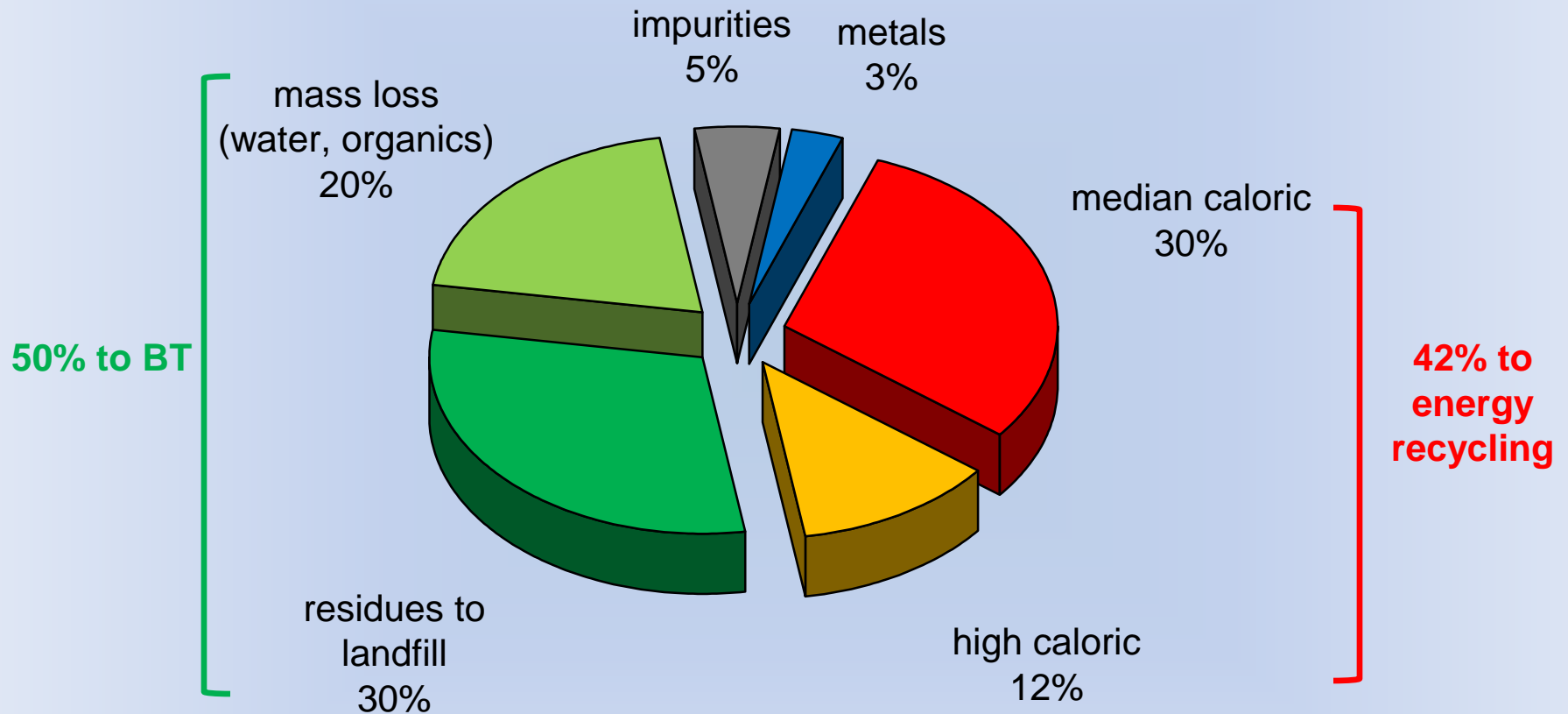

depends on local composition



Disposal ways of the **RDF** 2007 of all MBS, MBD and MPD plants (approx. **2.5 Mt/y**)

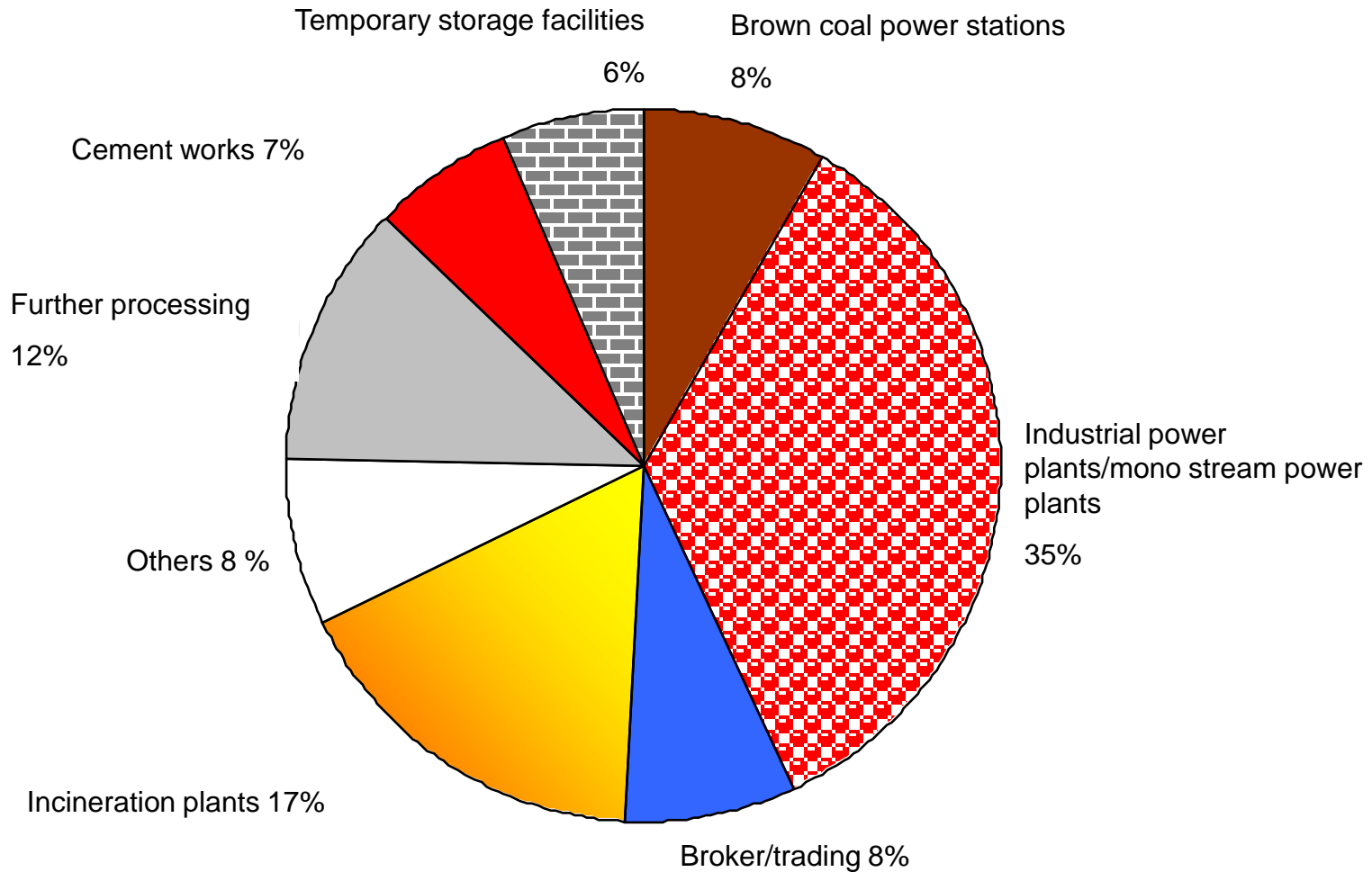

MBT as a raw material and fuel supplier



Mono stream power plants for the use of HCF

Capacity working/in building	approx. 5,056,500 t/y
Capacity permission approved/requested	approx. 2,457,000 t/y
Capacity projects	approx. 1,915,000 t/y
Total capacity	approx. 9,428,500 t/y

Current developments concerning HCF-powerplants in Germany

EUWID, 24.02.2009:

„Planned HCF-powerplant Elsterberg will not be build“

EBS-Kraftwerk Elsterberg wird nicht gebaut

Das geplante Ersatzbrennstoff-Kraftwerk im sächsischen Elsterberg wird nicht realisiert. Grund ist die finanzielle Schieflage des Wuppertaler Viskoseherstellers Enka. „Das Unternehmen steht kurz vor der Insolvenz“, erklärte der kaufmännische Leiter Christian Bartsch gegenüber EUWID. Um den Cash-Abfluss gering zu halten, soll daher das Werk im vogtländischen Elsterberg mit 380 Beschäftigten geschlossen werden. Damit sind auch die Pläne für das EBS-Kraftwerk am Standort vom Tisch. „Wir werden das Genehmigungsverfahren beenden“, so Bartsch.

Wie berichtet (EUWID 24/2008), hatte Enka mit dem Energieversorgungsunterneh-

„HCF-powerplant Meuselwitz files for insolvency“

EBS-Kraftwerk Meuselwitz stellt Insolvenzantrag

Das Ersatzbrennstoff-Kraftwerk Meuselwitz-Lucka im thüringischen Meuselwitz ist zahlungsunfähig. Vorletzten Freitag stellten die Betriebsgesellschaft Heizkraftwerk Meuselwitz-Lucka GmbH & Co. Betriebs-KG und ihre Gesellschafterin Heizkraftwerk Meuselwitz-Lucka GmbH Insolvenzantrag beim Amtsgericht Gera. Grund sei der Preiseinbruch am Abfallmarkt. Wie Geschäftsführer Werner Krüger gegenüber EUWID sagte,

Market for incineration-capacity is saturated

Implemented MBT plant types in Germany

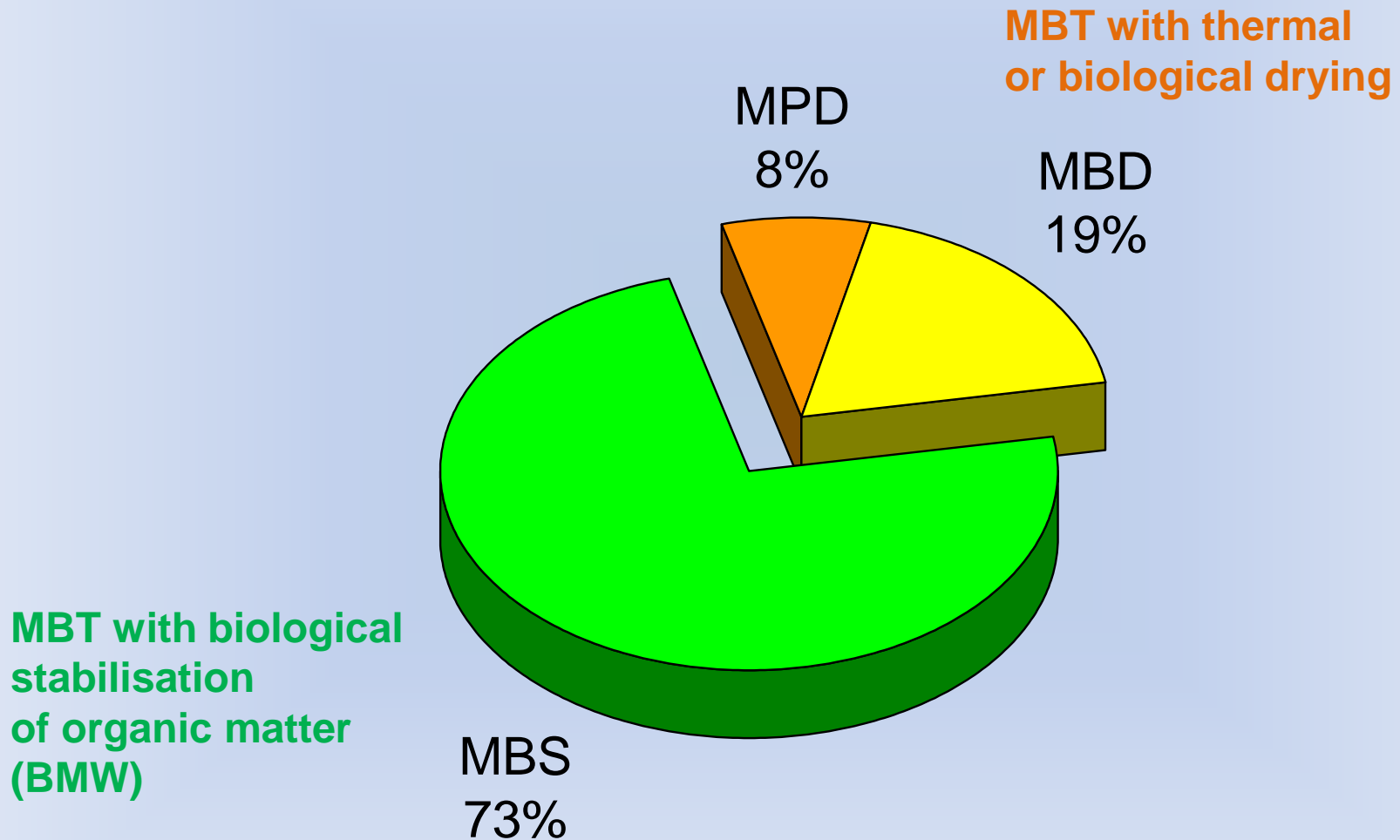

Used processes for BT (stabilisation) in german MBT (MBS)

First step of BT

21 MBT
with rotting
only
64%

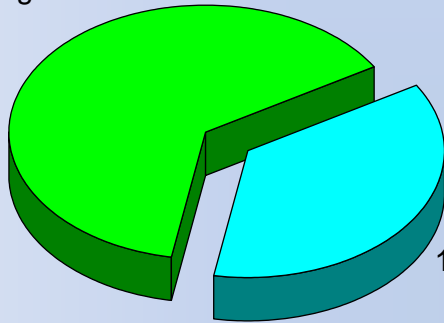

12 MBT
with
anaerobic
digestion
36%



AD-technologies

wet
5 plants
236,000 t/y

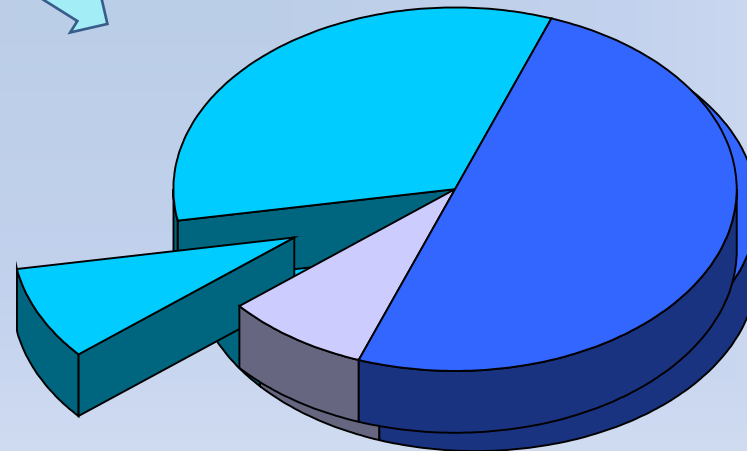

dry
6 plants
224,000 t/y

percolation
1 plants
85,000 t/y

wet AD in MBT Lübeck
55,000 t/y

MBT Cröbern only aerobic decomposition 300,000 t/y



MBT (RABA) Bassum with dry AD 100,000 t/y

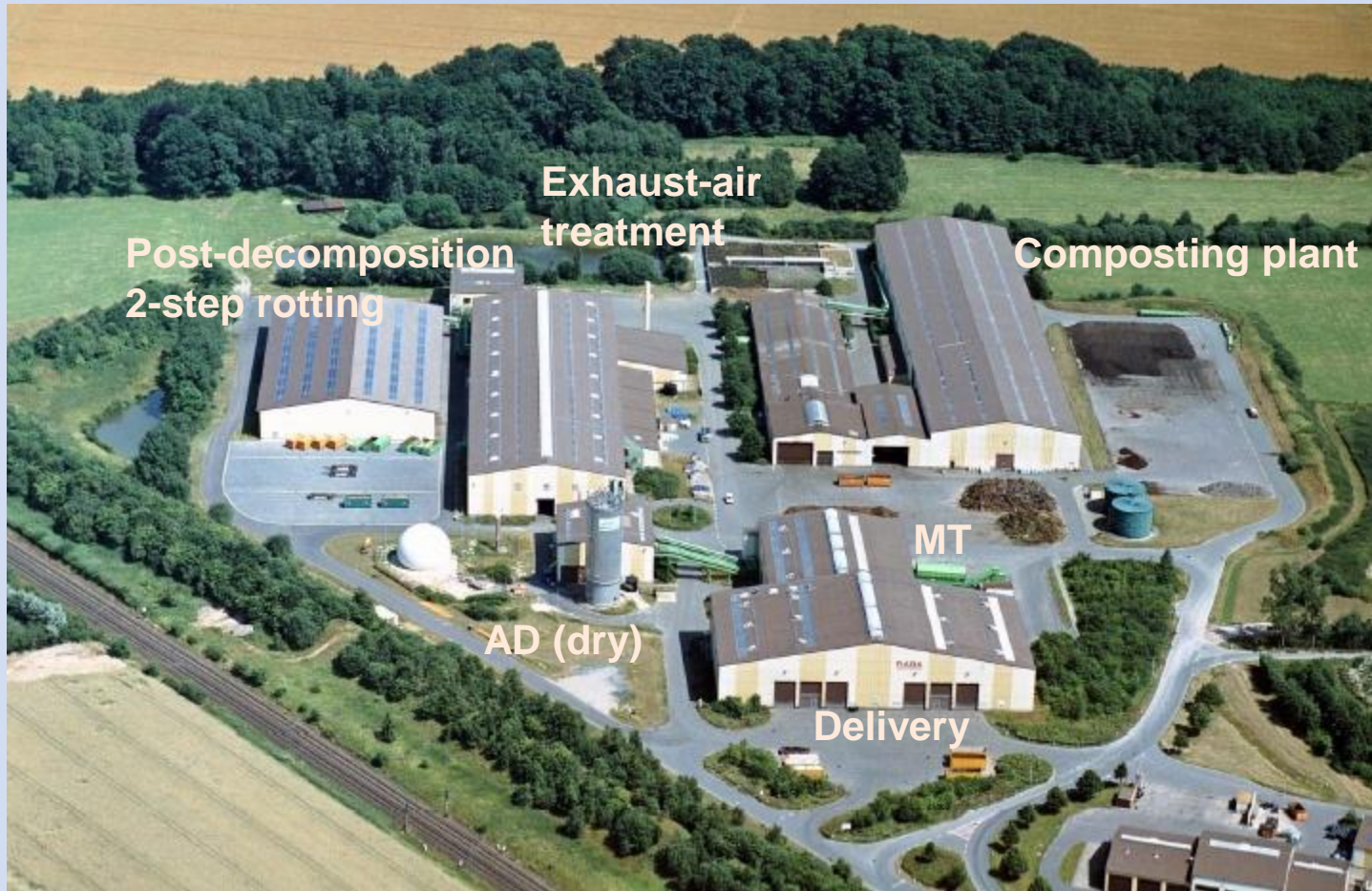

Relevance of AD in biological treatment of MSW and biowaste

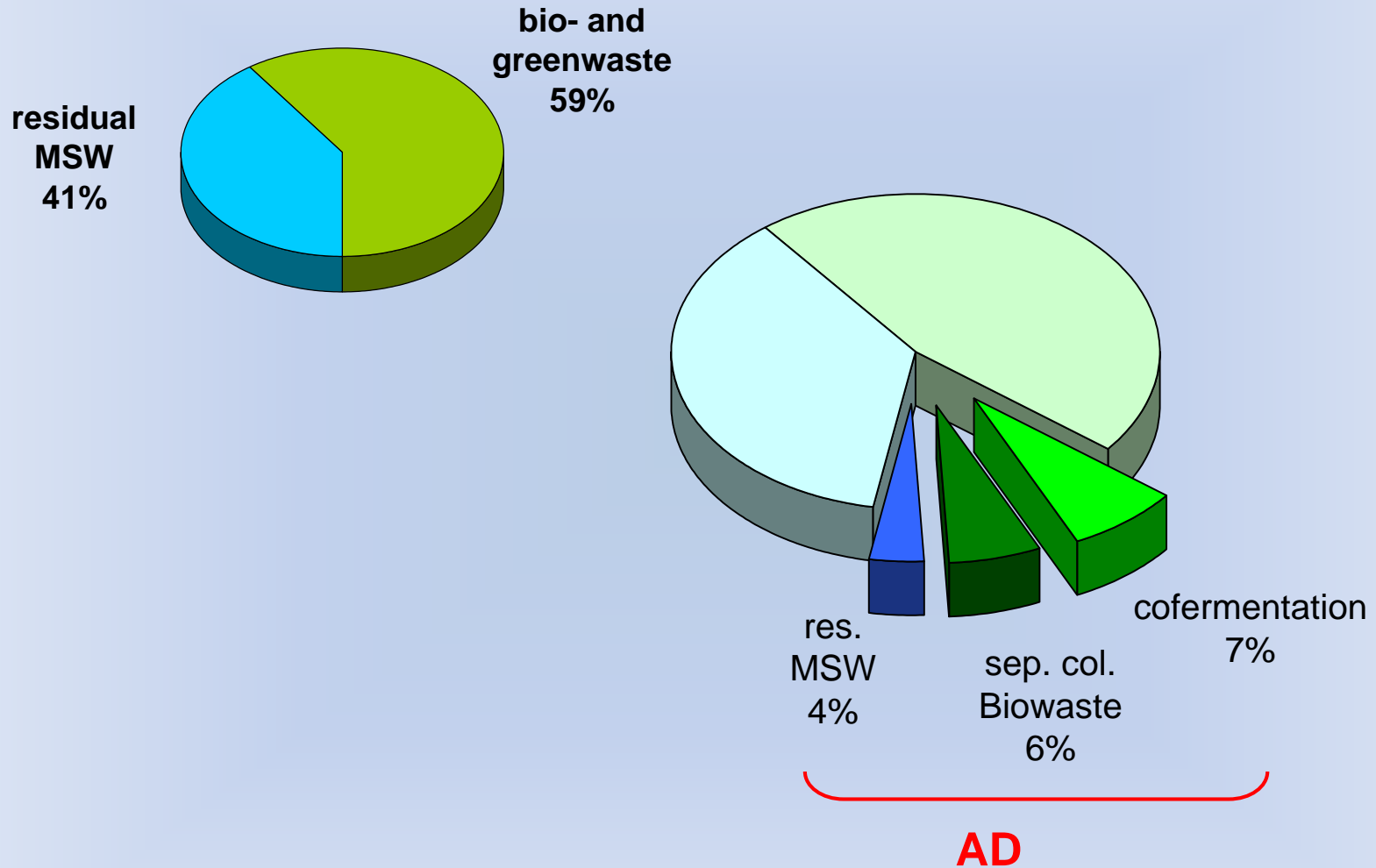

High potential and increasing interest in AD

AD of MSW and sep. col. biowaste in Germany total capacity: 1.3 Mt/y

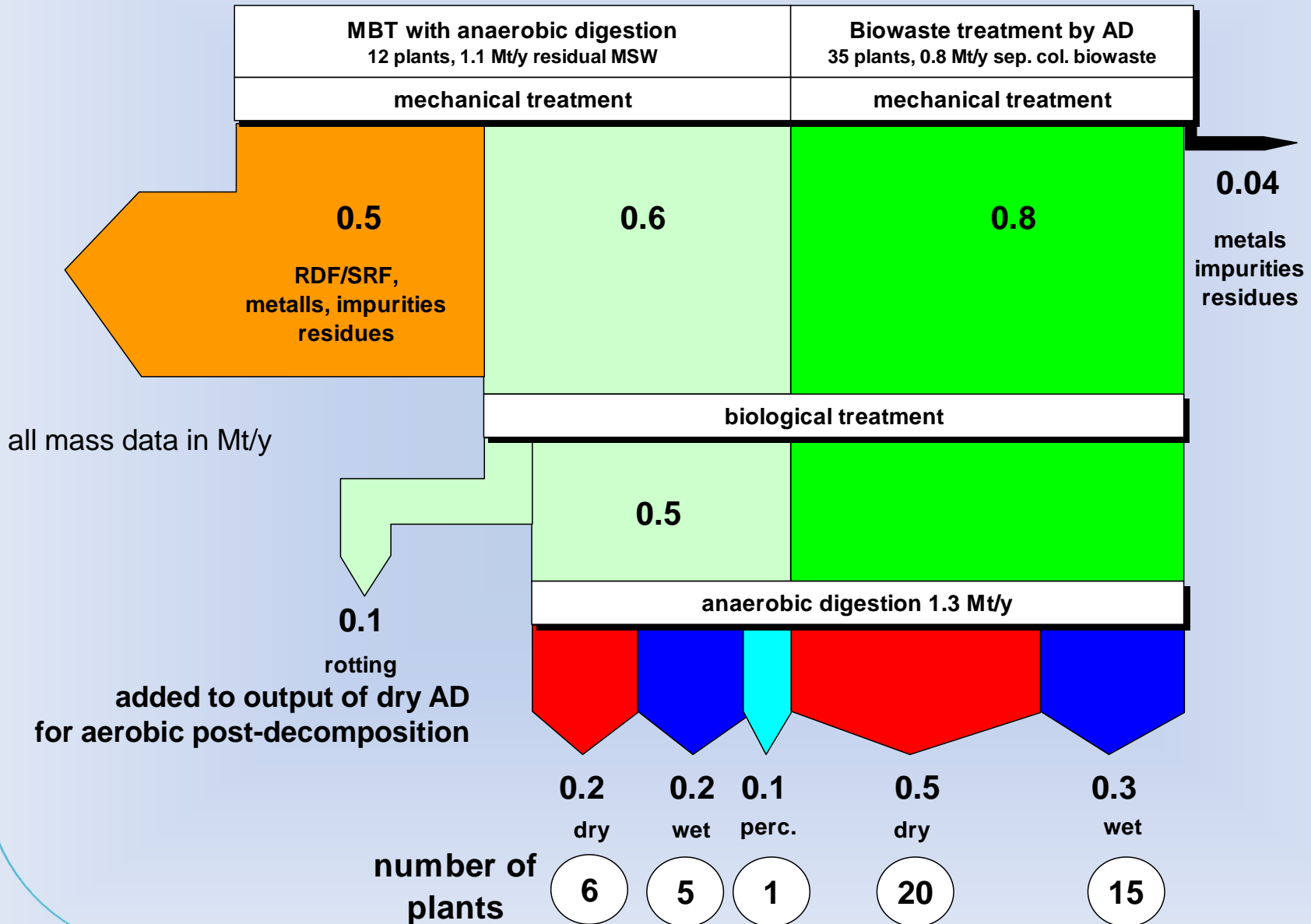

Main process concepts of AD in german MBT

1. dry (MI)

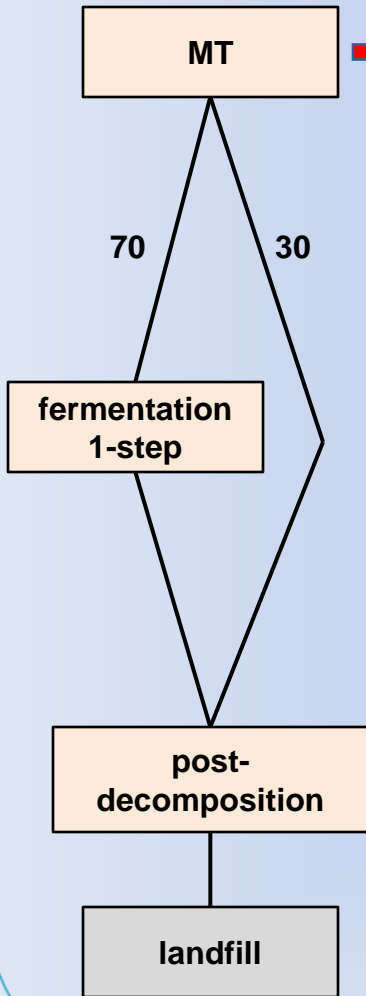

2. dry (H)

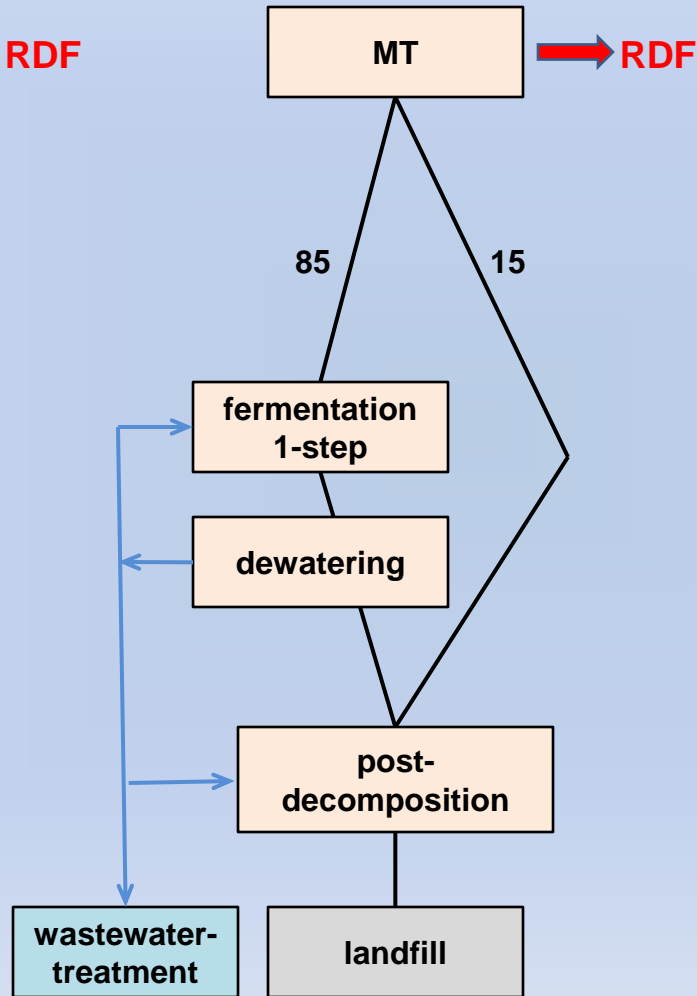

3. wet (HL)

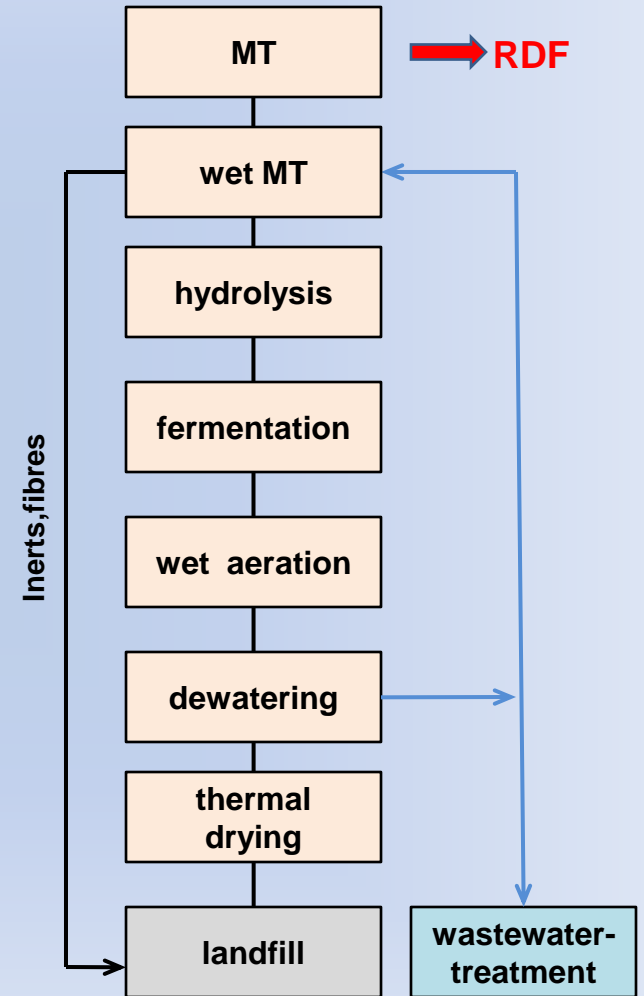

1. MBT Pohlsche Heide with dry AD (component current 70:30)



2. MBT Hanover with dry AD (85/15) 200,000 t/y



3. MBT Lübeck with wet AD and wet aeration 146,000 t/y



Retention time in the biological steps of MBT in Germany to successfully observing landfill requirements AbfAbIV

system	weeks
Wet AD + wet aeration	5
Dry AD + post decomposition	9 - 12
Only aerobic decomposition	6 - 16

Mass balance in MBT with different type of AD and aerobic post-decomposition in 3 different communities in germany

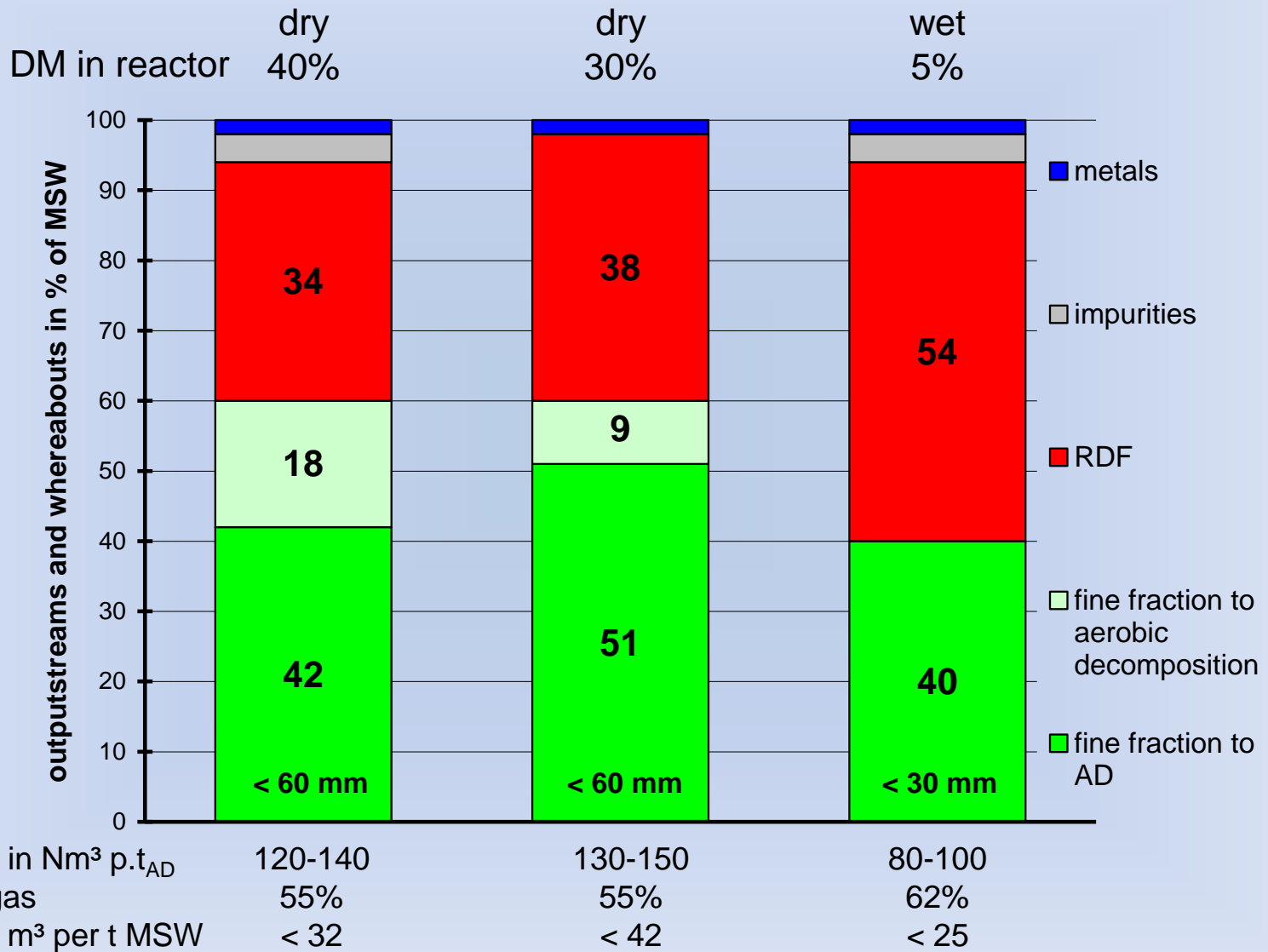

MBT Lübeck, mechanical treatment



Flowchart of the mechanical treatment in the MBT of Lübeck

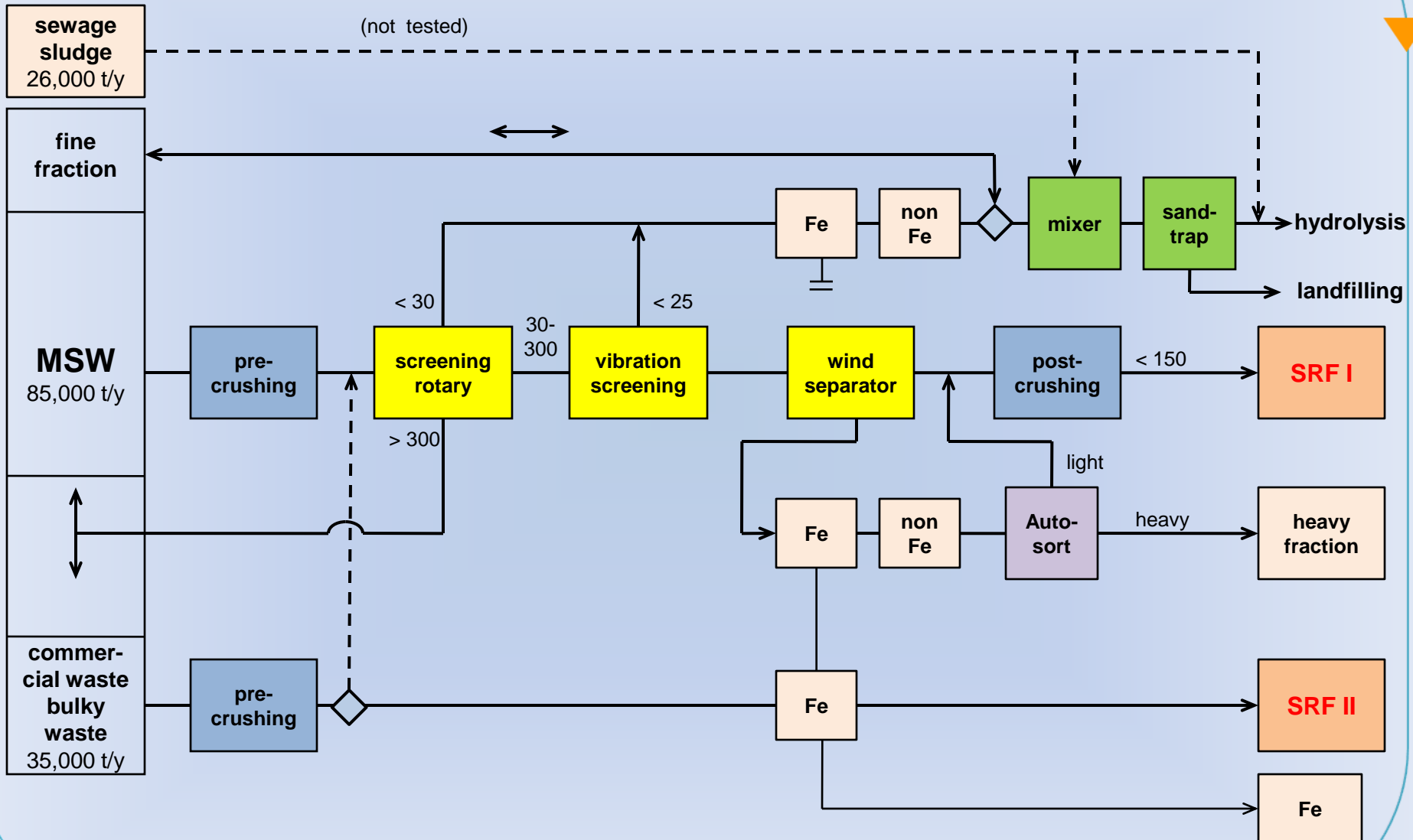

Flowchart of the biological treatment in the MBT of Lübeck and some of the optimization measures

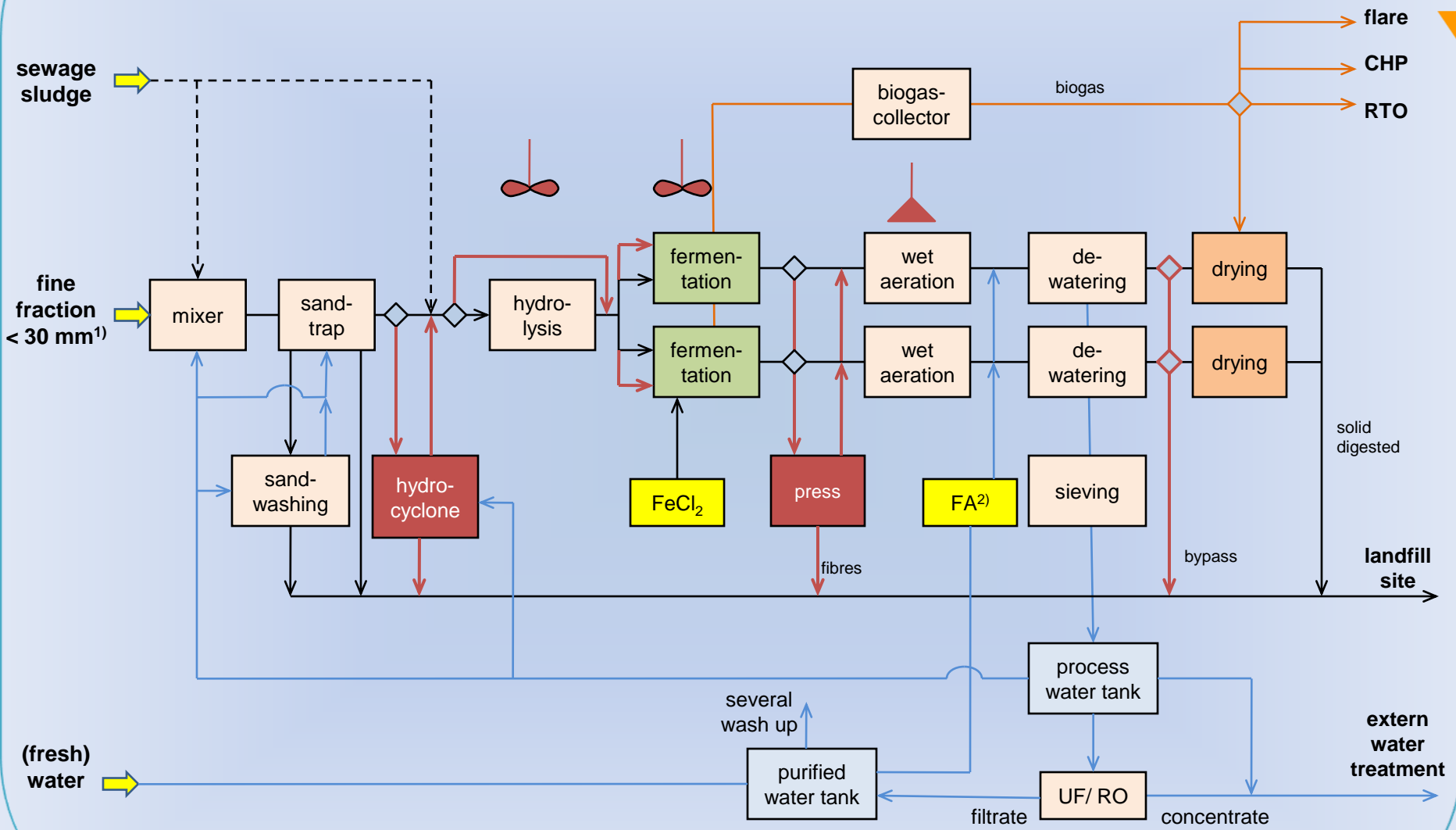

1) recently reduced from 40 to 30 mm

2) floccation aid

MBT with wet AD

main problems „inerts“ and „floating solids“

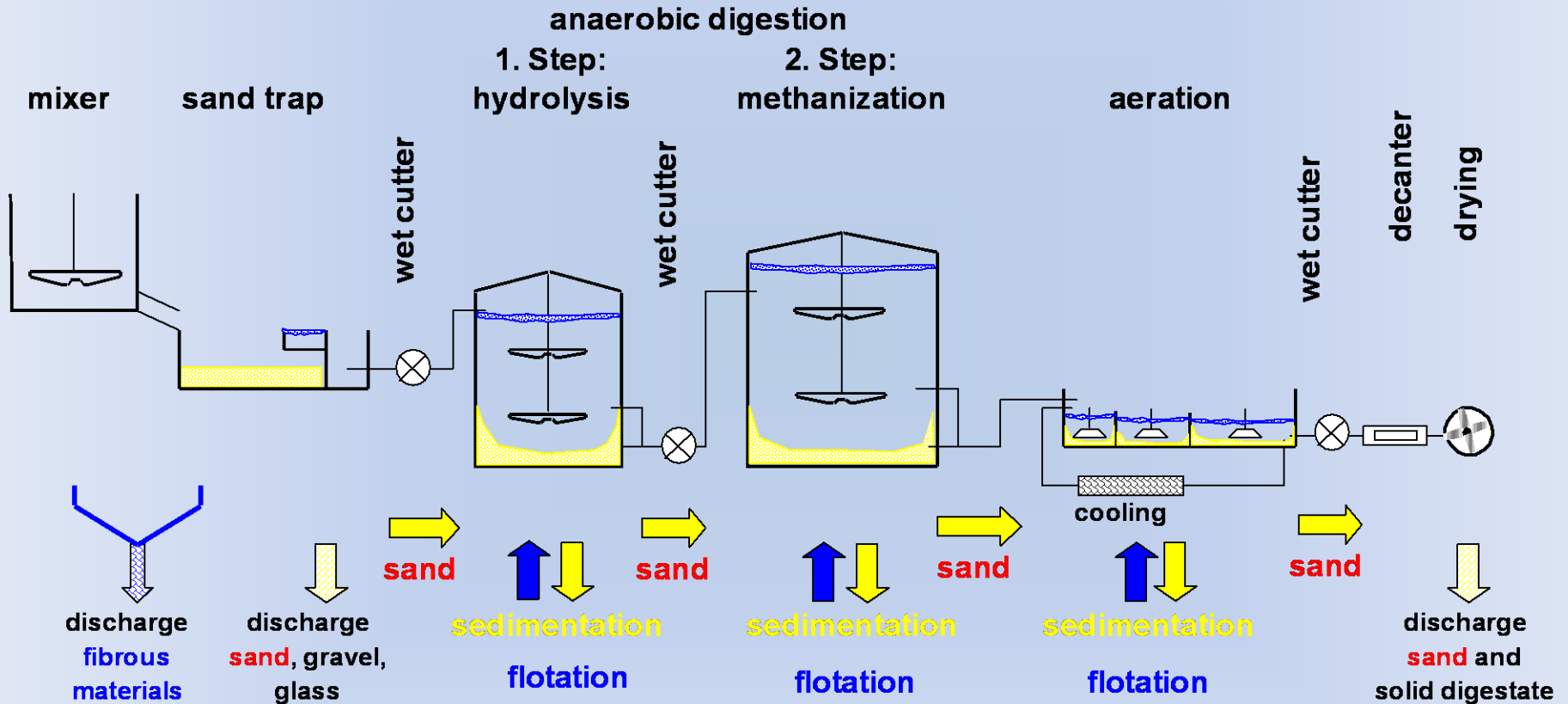

Grain size distribution

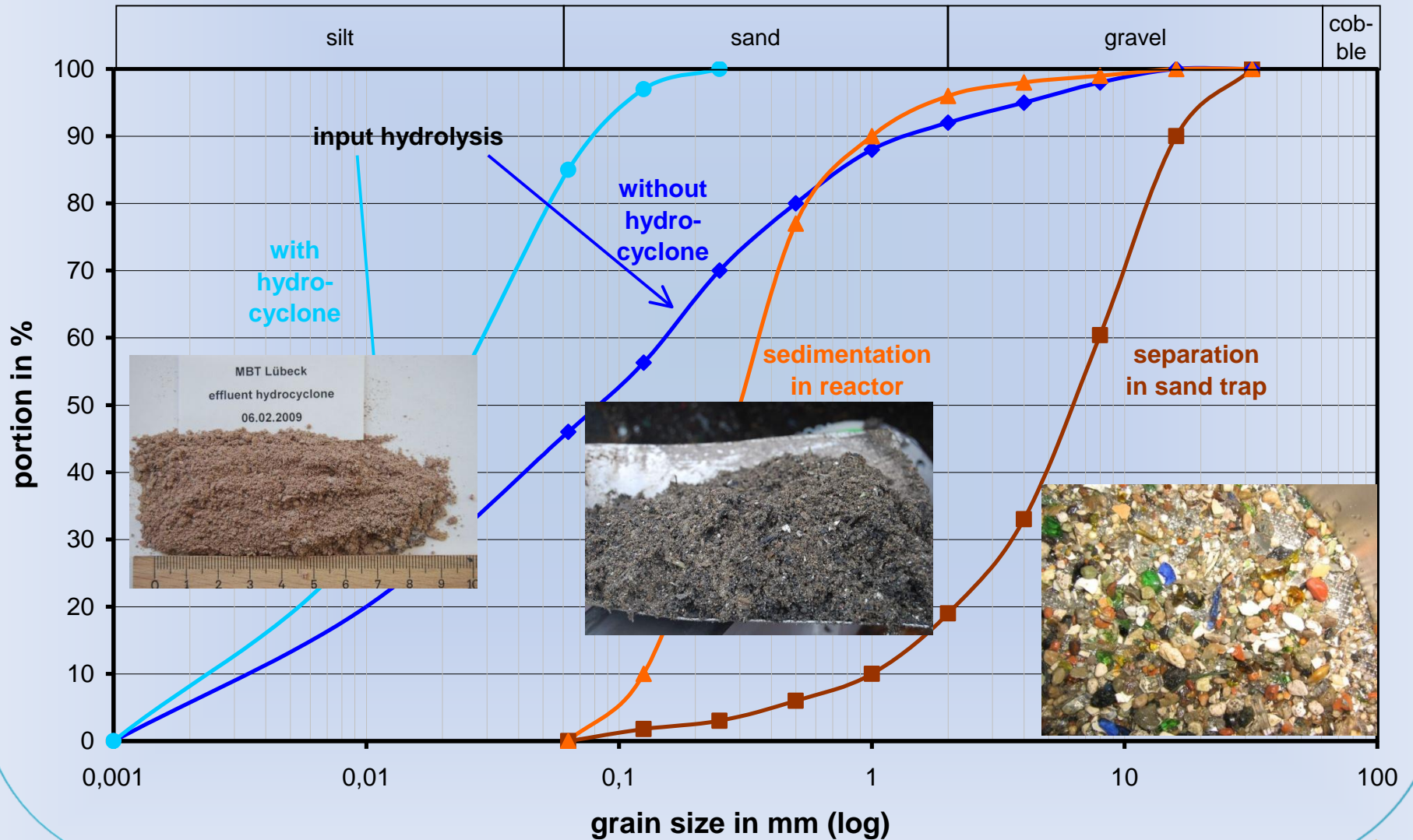

Sedimentation in fermentation reactor



manhole and
entrance for machine



Sand-digging with a
wheel loader

MBT Lübeck sedimentation in aeration



Cleaning Aeration



Aerator, damaged



New Aerator

MBT Lübeck – biological treatment

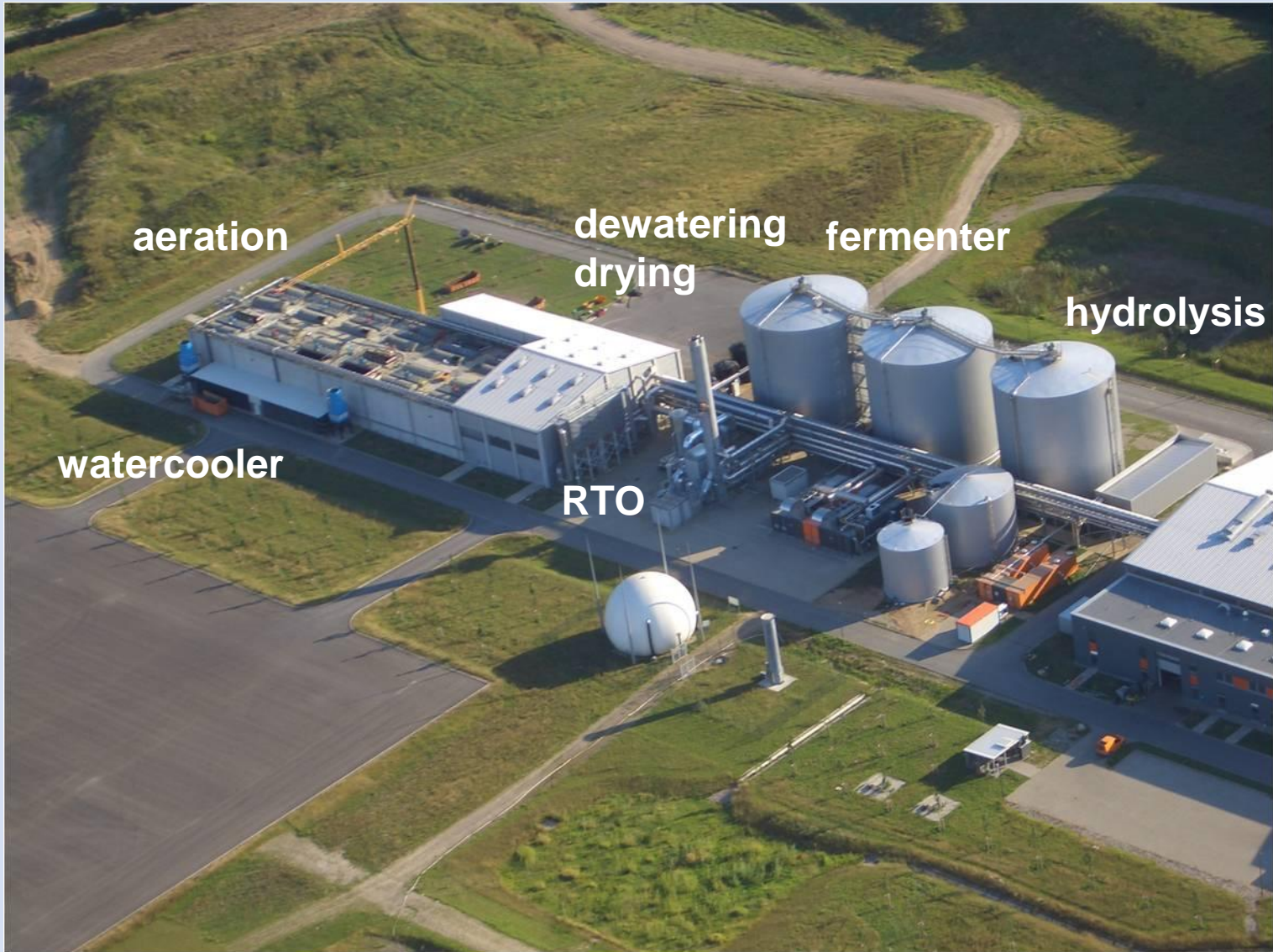

Main differences between dry and wet AD of MSW (1)

AD+PC (post decomposition) DM in reactor	Dry with PC > 40% DM	Dry with PC 25-35%DM	wet with wet aeration	note/ example
Input quality	low	middle	high	
Separation of light fraction	no	no	yes	swimming fibres
Separation of great inerts	better	yes	yes	> 15 mm
Separation of small inerts	no	no	yes	> 200 µm
Dewatering	no	yes	yes	
Thermal drying	no	no	yes	
Fresh water	small	middle	high	
Excess water	no	middle	high	
Prozess water treatment	no	it depends	yes	
Aerobic post-decomposition	yes	yes	alternative	

Main differences between dry and wet AD of MSW (2)

AD+PC fine fraction to post rotting	Dry with > 40%	Dry with 25-35%	wet with wet aeration	note/ example
Wet aeration	no	no	yes	Alternative a. post-decomp. possible
Cooling for aeration	no	no	yes	
Corrosion, abrasion	small	middle	high	
Exhaust air from BT	high	high	small	It depends on the type of rotting system
SiO ₂ --problems in RTO	yes	yes	no	But smaller than in only rotting systems
Methane production / methan yield	middle	high	low	Depends on % to AD
Problems with N ₂ O in exhaust air	no	it depends	at times	
Problems with landfilling (AbfAbIV)	no	no	no ¹	1)

1) when reducing fraction < 35 mm

Conclusions

- **MBT with recycling metals, wood, plastics and RDF/SRF can be more efficient than incineration only**
- **MBT with composting or AD is not in opposition to separate collection**
- **Separate collection of bio- and greenwaste is an usefull precondition to produce a compost with high quality**
- **The energy efficiency of MBT depends on recycling of RDF**
- **The AD of biowaste becomes more due in Germany**
- **The AD of BMW from MSW and biowaste will go to dry AD**
- **The plants with wet AD are still in optimization and refurbishment**
- **The inerts > 200 μm must be removed from organic suspension before first digester/fermenter via hydro cyclone**
- **A separation of inerts with a sand trap allone is not enough**
- **After refurbishment of the MBT with wet AD:**
 - *process management will be more stable*
 - *service life will be increased*
 - *spare parts- and abrasion costs will be decreased*

Thank you for your attention

Dr.-Ing. Ketel Ketelsen

iba Ingenieurbüro für Abfallwirtschaft und Energietechnik GmbH
Engineering consultancy for waste and energy management



+49 511 34 91 90-50



+49 511 34 91-99

E-Mail: k.ketelsen@iba-hannover.de

iba GmbH, Hanover – services

iba offers special engineering services in the area of waste management, disposal, and environmental protection. iba focuses its current activity on the following areas

- Plant engineering

- Mechanical processing and screening plants including production of refuse derived fuels (RDF)
- MBT with anaerobic digestion and / or rotting / biological drying
- Composting plants
- Anaerobic digestion plants
- Exhaust air treatment systems

- Weak-point-analysis and situation reports for plants in operation

- Optimizing of plants and plant-operation

iba GmbH, Hanover – services

- Development of analytical standards; planning, organizing and realizing of laboratory tests
- feasibility studies
- concepts and programs for waste management
- analyses of various types of refuse
- disposal and waste management concepts for companies in trade and industry
- energy utilization of residual and refuse derived fuels
- renewable energy sources used in fermentation process
- investigations / analysis regarding the biological decomposition and biodegradability of wastes (gasification, oxygen demand, respiration rate),
- tenders for services in waste management